

1 Utilizzo

Importato da GRUPPO STAMPLAST, questo articolo è in grado di soddisfare qualsiasi esigenza architettonica e strutturale, inoltre ha un'eccellente resistenza agli sbalzi di temperatura, agli urti e alla compressione. Disponibile in diverse colorazioni.

VE19S-01
Nuvola bianco satinato
19x19cm



VE19S-03
Nuvola verde satinato
19x19cm



VE19S-06
Nuvola celeste satinato
19x19cm



VE19S-02
Nuvola rosa satinato
19x19cm



2 Modelli

COD.	MOD.*					
VE19S-01	19x19		6	360	110x110x120	2,240 kg/pz
VE19S-03	19x19		6	360	110x110x120	2,240 kg/pz
VE19S-06	19x19		6	360	110x110x120	2,240 kg/pz
VE19S-02	19x19		6	360	110x110x120	2,240 kg/pz

*MISURE IN CENTIMETRI

Materiali

Vetro

Colori



3 Caratteristiche tecniche

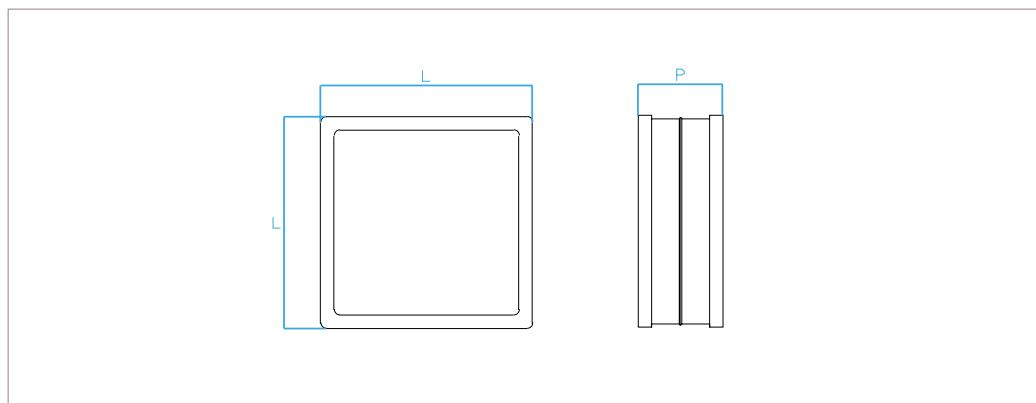

MOD.*	L*	P*
19x19	19	8

*MISURE IN CENTIMETRI

vetrocemento nuvola satinato 19x19